

**1 1/4" (32mm) DIAMETER  
SWING UP GRAB BAR  
WITH INTEGRAL  
TOILET PAPER HOLDER**

**125-SWING-  
UP-PH**

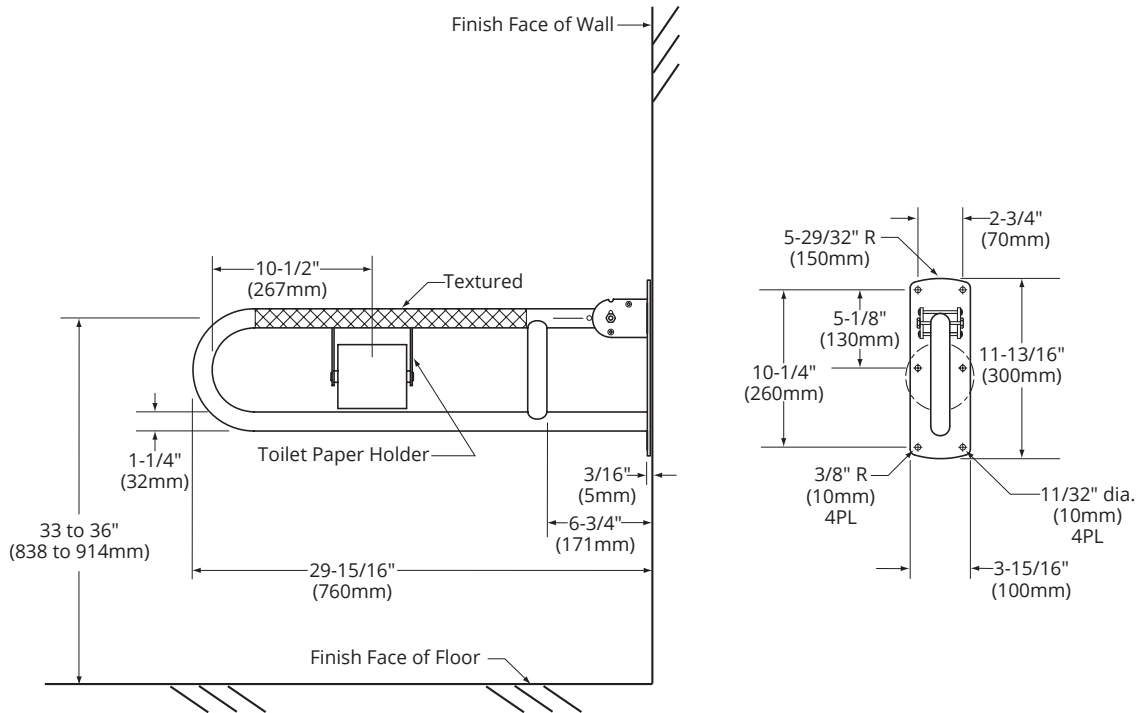

**CONSTRUCTION:**

**Tube** - Fabricated of type 304 stainless steel and assembled into a swivel hinge. Exposed surfaces polished to a #4 satin-finish and knurled grip. Detent holds bar in vertical position.

**Wall Retaining Clip** - Stainless steel.

**Back Plate** - 3/16" (4.5mm) thick, one piece stainless steel design.

**MOUNTING:**

Unit absolutely must be secured to in-wall reinforcement backing. Unit is attached with 4 bolts with a minimum 1/4" (6mm) diameter. Mounting bolts not furnished. Screws (not furnished).

**SPECIFICATIONS:**

Grab bars have been designed and tested to withstand 500 lbs. downward pull when properly installed.

**Swing Up Grab Bar with Integral Toilet Paper Holder shall be Model 125TPH of Gamco Commercial Restroom Accessories, A Division of Bobrick Washroom Equipment, Inc., One Gamco Place, Durant, OK, 74701-1910**